

# VR11 LADDER SCHEMATIC

NATIONAL REFRIGERATION PRODUCTS  
 458 IMPERIAL COURT  
 BENSLEM, PA 19020-7327

DRAWN BY: DTM	DWG NO.: NRP-LS-012	REV. A
------------------	------------------------	-----------

SCALE: N/A	DATE: JANUARY 12, 1998
------------	---------------------------

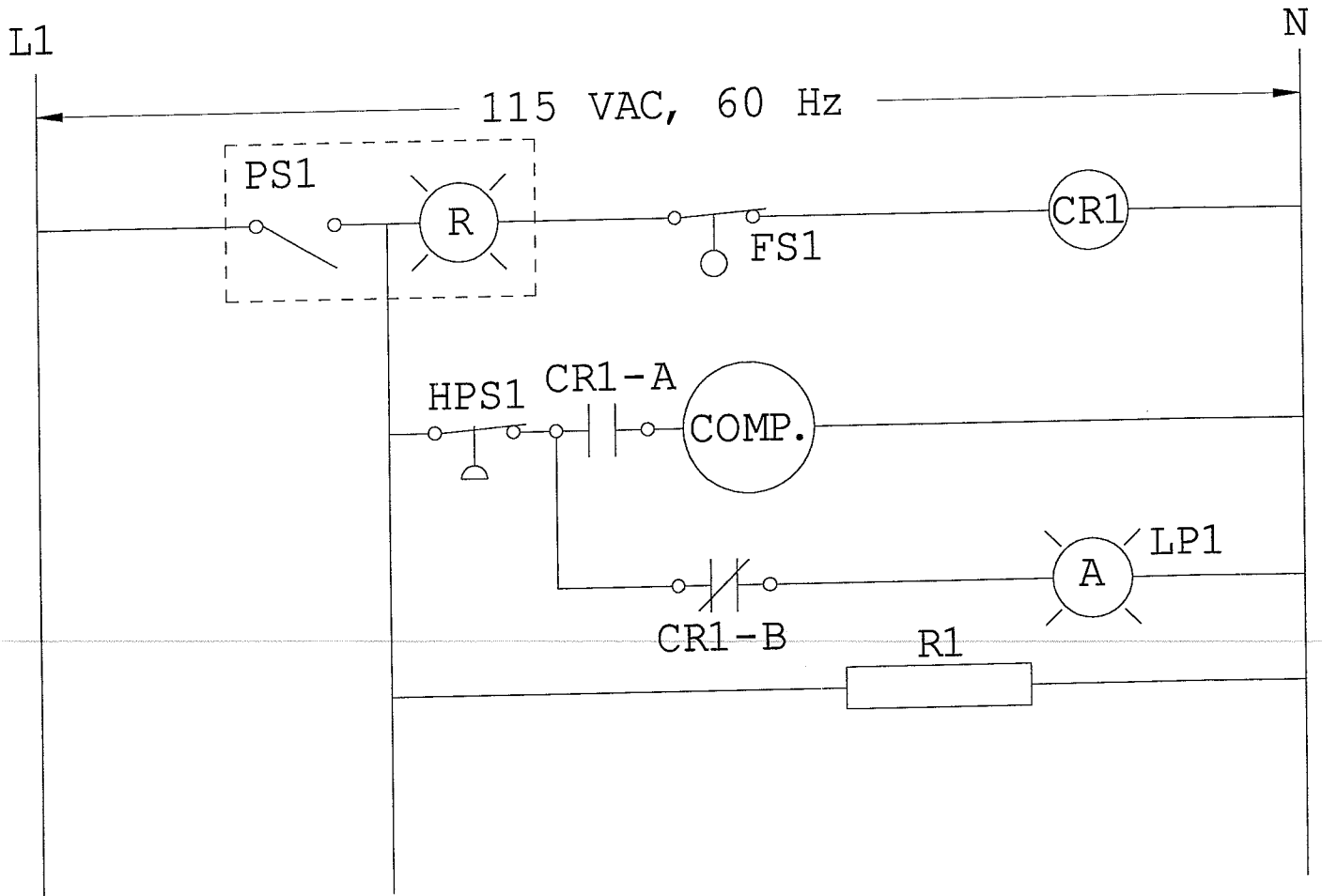

## LEGEND:

COMP. - WELSCH COMPRESSOR  
 CR1 - SHUT OFF COIL  
 CR1-A - CR1 CONTACTS NORMALLY OPEN  
 CR1-B - CR1 CONTACTS NORMALLY CLOSED  
 FS1 - FLOAT SWITCH  
 HPS1 - **LOW** PRESSURE SWITCH (30 PSI)  
 L1 TO N - LINE VOLTAGE (115 VAC)  
 LP1 - TANK FULL LAMP, AMBER LAMP  
 PS1 - ON/OFF SWITCH WITH RED LAMP  
 R1 - HEATER ON OIL SEPARATOR